

Fluid Level/Temperature Gauges

Specification



Construction:

Lens Transparent polyamide.
Lens base Nylon 66.
Shroud High impact polystyrene.
 No aluminium content.

Bolts:

Steel.

Seals:

Nitrile.

Maximum working pressure:

1 bar.

Working temperature:

-30°C to +90°C.

Fluid compatibility:

Mineral and petroleum based oils.

Note:

A 500mm model with metal shroud finished in black available.

Recommended bolt tightening torque:
 10 Nm maximum.

Thermometer scale range:

+30°C to +90°C.

Temperature Indicator:

Blue alcohol.

Note:

1. Locate seals in mounting recess before fitting.
2. Select the size required by studying the installation details to determine a part number.

Size 1 Installation Details

For 'through hole' mounting:

Hole size	-Thread-	
	M10	M12
Preferred	11.0	13.0
Maximum	13.0	14.0

For tapped holes:

Holes to be tapped square to mounting face.

Tolerance on hole centres: +0.5
 -0.2

For welded back nuts:

The above details should be combined.

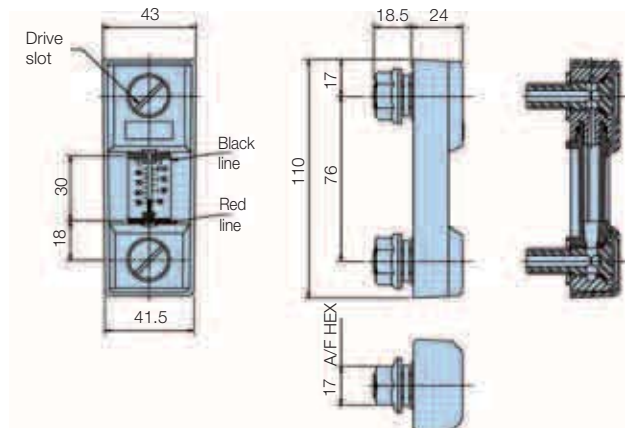

Installation and Application Information

Simple to Install

The universal fixing is designed for either front or rear fixing. Just two holes in the tank – threaded for front fixing – and the gauge is ready to install. After positioning the gauge the bolts are simply tightened to provide a secure seal. There is no fear of leakage with the square section seals and the two-point mounting system eliminates problems with tank distortion. M10 and M12 bolt thread options are available.

Easy to Read

The high-visibility lens is one-piece for added security and moulded in shatterproof, transparent polyamide for an accurate and clear oil level and temperature indication. Further gauge protection is provided by a specially designed shroud moulded in high-impact, black polystyrene.

Size 1 Ordering Information

Standard products table

Part number	Supersedes	Description	Centres	Thread	Max temp	Weight
FL69121	FLT.121	Fluid level/temp	76mm	M10	90°C	0.13Kg
FL69123	FLT.123	Fluid level/temp	76mm	M12	90°C	0.13Kg
FL69111	FL.111	Fluid level	76mm	M10	90°C	0.13Kg
FL69113	FL.113	Fluid level	76mm	M12	90°C	0.13Kg

Note 1: Part numbers featured with bold highlighted codes will ensure a 'standard' product selection.

Note 2: Alternate displayed part number selection will require you to contact Parker Filtration for availability.

Size 2 Installation Details

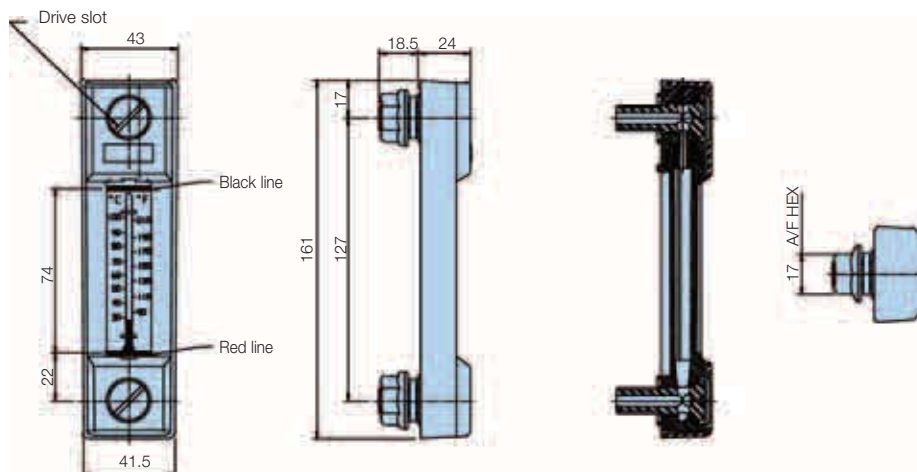

Size 2 Ordering Information

Standard products table

Part number	Supersedes	Description	Centres	Thread	Max temp	Weight
FL69221	FLT.221	Fluid level/temp	127mm	M10	90°C	0.15Kg
FL69223	FLT.223	Fluid level/temp	127mm	M12	90°C	0.15Kg
FL69211	FL.211	Fluid level	127mm	M10	90°C	0.15Kg
FL69213	FL.213	Fluid level	127mm	M12	90°C	0.15Kg

Note 1: Part numbers featured with bold highlighted codes will ensure a 'standard' product selection.

Note 2: Alternate displayed part number selection will require you to contact Parker Filtration for availability.

Size 3 Installation Details

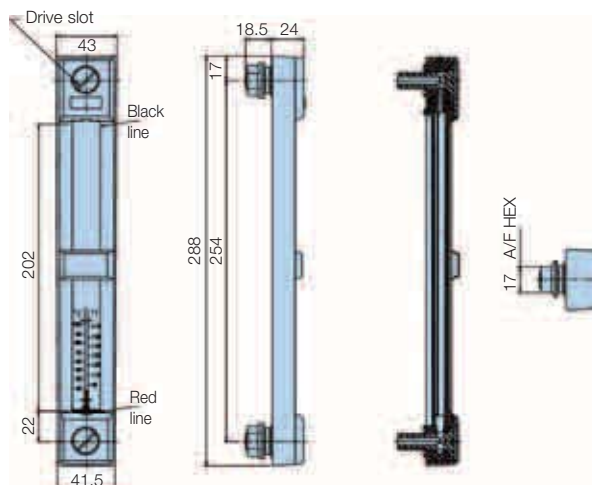

Size 3 Ordering Information

Standard products table

Part number	Supersedes	Description	Centres	Thread	Max temp	Weight
FL69321	FLT.321	Fluid level/temp	254mm	M10	90°C	0.23Kg
FL69323	FLT.323	Fluid level/temp	254mm	M12	90°C	0.23Kg
FL69311	FL.311	Fluid level	254mm	M10	90°C	0.23Kg
FL69313	FL.313	Fluid level	254mm	M12	90°C	0.23Kg

Note 1: Part numbers featured with bold highlighted codes will ensure a 'standard' product selection.

Note 2: Alternate displayed part number selection will require you to contact Parker Filtration for availability.